

DP11-23-22 (DP24kC)

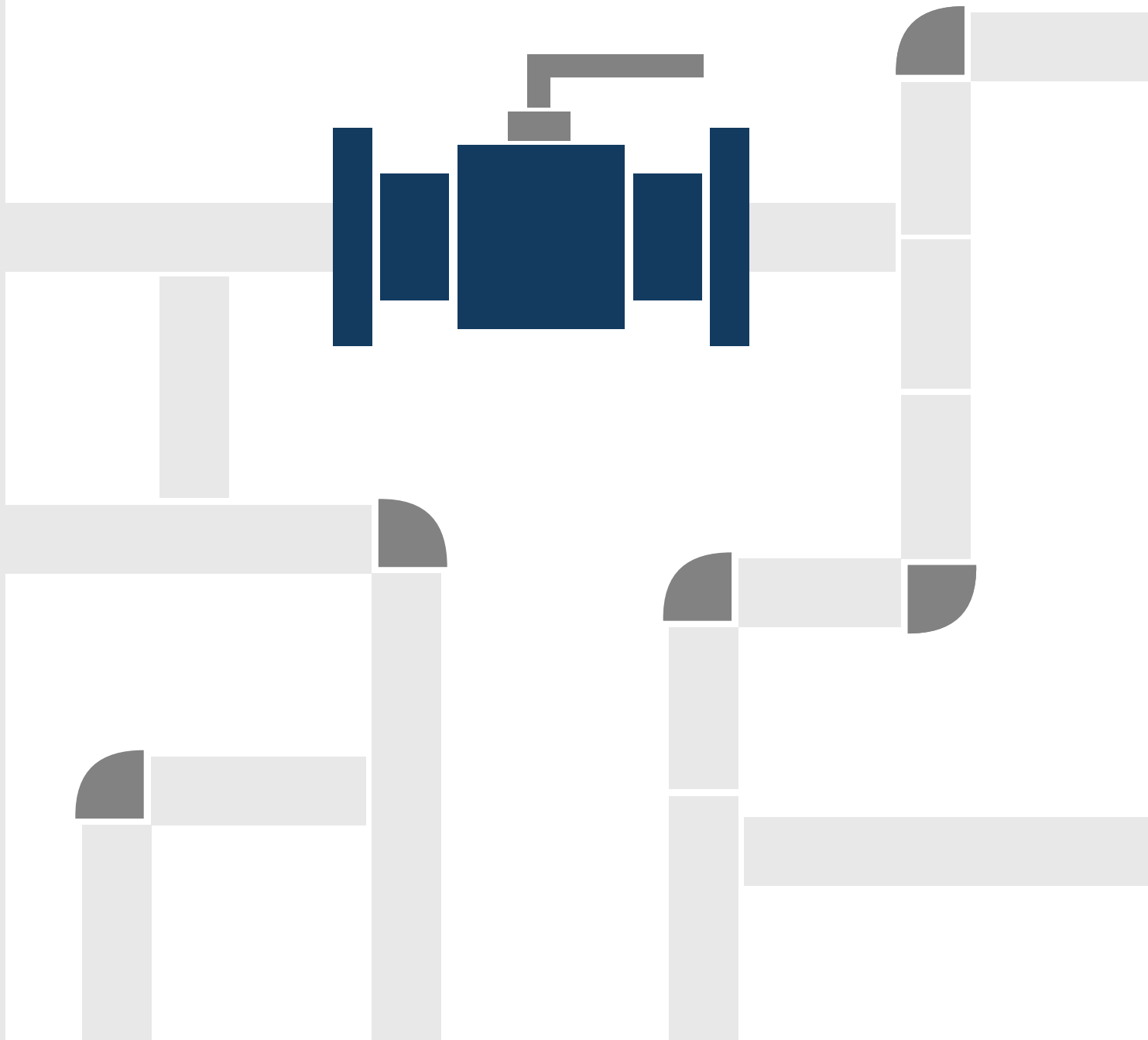

DP11-23-22 (DP24kC)

KUREK KULOWY KOŁNIERZOWY Z PEŁNYM PRZELOTEM - JEDNOCZĘŚCIOWY



ZAKRES ŚREDNIC
NPS 1/2 ÷ NPS 10



CIŚNIENIE
CL 150 ÷ CL 300



TEMPERATURA
-50°C ÷ +250°C

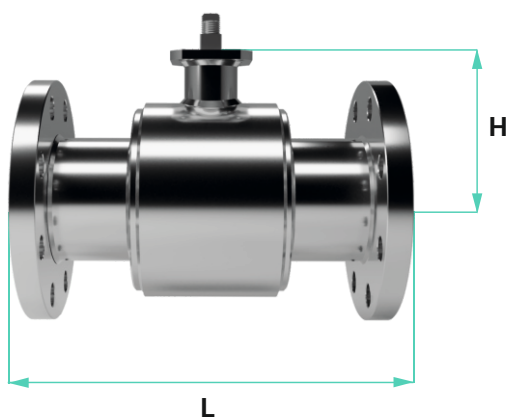

NPS	1/2	3/4	1	1 1/4	1 1/2	2	2 1/2	3	4	5	6	8	10
DN	15	20	25	32	40	50	65	80	100	125	150	200	250
Przełot	15,9	20	25	32	40	50	62	75	98	130	156	200	248
L - CL 150	108	117	127	140	165	178	190	203	229	330	394	457	533
L - CL 300	140	152	165	178	190	216	241	282	305	330	403	502	568
Masa (kg)	1,8	2,6	3,6	5,3	6,1	8,8	13,2	17,5	28,2	45	78,9	135,4	160
H	44	46	57	61	65	91	100	110	141	166	213	238	301
Sterowanie	D	D	D	D	D	NP/D	NP/D	NP/D	NP/D	NP/D	NP/P	NP/P	NP/P

D - dźwignia NP/D - dźwignia oraz przystosowanie do montażu napędu NP/P - przekładnia ręczna

WYKONANIE

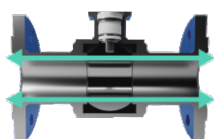

PEŁNY PRZELOT

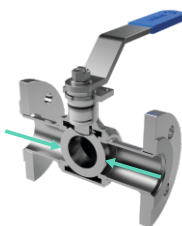

KLASA SZCZELNOŚCI A

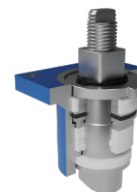

DŁAWICA BEZOBSŁUGOWA

STEROWANIE



DŹWIGNIA



PRZEKŁADNIA RĘCZNA



NAPĘD ELEKTRYCZNY LUB PNEUMATYCZNY

OPCJA



FIRE SAFE
EN-ISO 10497:2010



TA - LUFT
PN-EN ISO 15848-1
VDI 2440

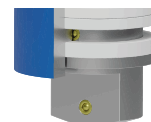

ATEX
2014/34/UE
ANTYSTATYCZNY

WERSJE MATERIAŁOWE

Rodzaj materiału	Stal węglowa		Stal stopowa nierdzewna										Inne
Oznaczenie	11	12	21	22	23	24	25	26	41	42	43 Duplex	44 Hastelloy	
Kadłub (korpus)	P355/S355	P235/S235	1.4541	1.4301	1.4571	1.4571	1.4571	1.4404	1.4539	1.4931	1.4462	2.4602	według wymagań Klienta
Przyłącze	P355/S355	P235/S235	1.4541	1.4301	1.4541	1.4571	1.4571	1.4571	1.4539	1.4931	1.4462	2.4602	
Organ zamykający (kula)	1.4301	1.4301	1.4301	1.4301	1.4301	1.4404	1.4571	1.4404	1.4539	1.4931	1.4462	2.4602	
Wał (trzcień)	1.4305	1.4305	1.4305	1.4305	1.4305	1.4404	1.4571	1.4404	1.4539	1.4931	1.4462	2.4602	
Uszczelnienie kuli	PTFE, PTFE + włókno szklane 25%												
Pakiet uszczelniający	PTFE, PTFE + włókno szklane 25%												

STEROWANIE KURKÓW KULOWYCH - DŹWIGNIA

DN	W	H1	s	Typ	Funkcja
15	147	48	8 x 8	A	standard
20 - 25 - 32	167	59	10 x 10	A	
40	217	59	10 x 10	A	
50	280	61	17 x 17	A	
65 - 80	360	61	17 x 17	A	
100 - 125	472	23	24 x 24	B	
150	672	23	24 x 24	B	opcja

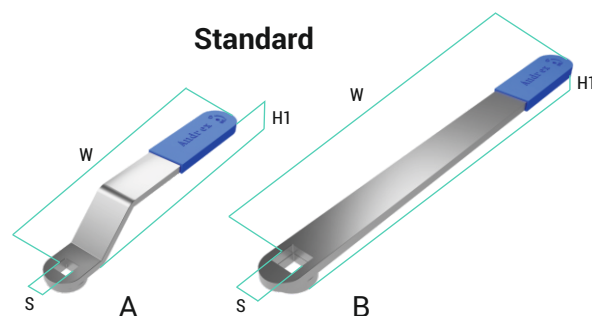

STEROWANIE KURKÓW KULOWYCH - KOLUMNA

DN	S	a	H standard	Typ	H max
15	8 x 8	5	100	KL1 - 100	zgodnie z zamówieniem
20	10 x 10	5	100	KL2 - 100	
25	10 x 10	5	100	KL2 - 100	
32	10 x 10	5	100	KL2 - 100	
40	10 x 10	5	100	KL2 - 100	
50	17 x 17	6	100	KL3 - 100	
65	17 x 17	6	100	KL3 - 100	
80	17 x 17	6	100	KL3 - 100	
100	24 x 24	8	100	KL4 - 100	
125	24 x 24	8	100	KL4 - 100	
150	24 x 24	8	100	KL4 - 100	
200	42 x 42	12	100	KL5 - 100	
250	42 x 42	12	100	KL5 - 100	

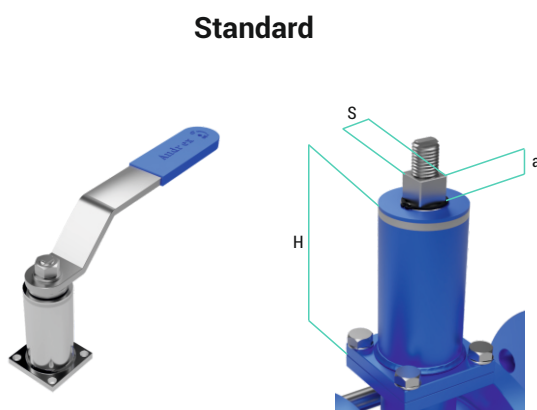

OPCJE WYKONANIA STEROWANIA



z możliwością zastosowania
kłódki, plomby



z zabezpieczeniem przed
przypadkowym przesterowaniem



z czujnikami
sygnalizacji krańcowej



z grzechotką



kwasoodporna



przesunięta w poziomie



wykonanie specjalne



dźwignia sprężysta

STEROWANIE KURKÓW KULOWYCH PRZEKŁADNIA RĘCZNA**



standard



z kolumną



z czujnikami sygnalizacji
krańcowej



z łańcuchem

NAPĘD PNEUMATYCZNY** NAPĘD ELEKTRYCZNY**



- jednostronny
- jednostronny z czujnikami sygnalizacji krańcowej
- jednostronny z czujnikami sygnalizacji krańcowej i elektrozaworem
- dwustronny z czujnikami sygnalizacji krańcowej
- dwustronny z czujnikami sygnalizacji krańcowej i elektrozaworem
- wykonanie specjalne

** wymiary dostępne na zapytanie

PRZYSTOSOWANIE POD NAPĘD

DN	d1	d3	S	a	H	Typ	H max
15	65	50	14 x 14	14	50	F 05	
20	65	50	14 x 14	15	75	F 05	
25	65	50	14 x 14	15	75	F 05	
32	65	50	14 x 14	15	75	F 05	
40	65	50	14 x 14	15	75	F 05	
50	90	70	17 x 17	18	60	F 07	
65	90	70	17 x 17	18	60	F 07	
80	90	70	17 x 17	18	60	F 07	
100	125	102	22 x 22	25	76	F 10	
125	125	102	22 x 22	25	76	F 10	
150	125	102	22 x 22	25	76	F 10	
200	150	125	27 x 27	30,5	97	F 12	
250	150	125	27 x 27	30,5	97	F 12	

zgodnie z zamówieniem

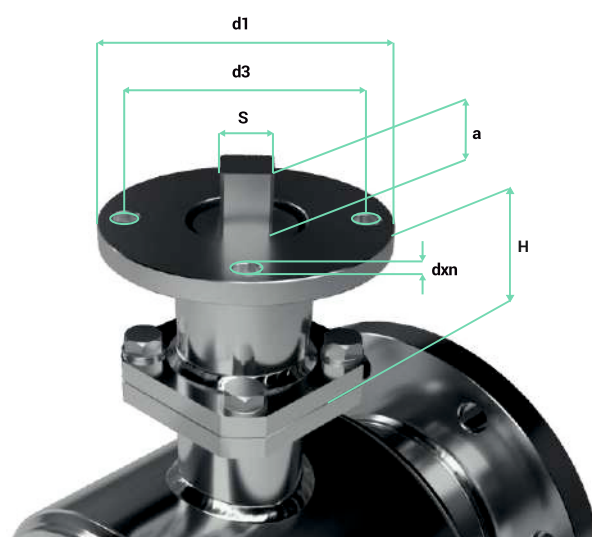

PRZYSTOSOWANIE POD WYPOSAŻENIE OPCJONALNE

DN	D	D1	□A	g	dxn	Funkcja
15	56	42	50	8	M6x4	
20	65	50	50	8	M6x4	
25	65	50	50	8	M6x4	opcja
32	65	50	50	8	M6x4	
40	65	50	50	8	M6x4	
50	70	70	62	8	M8x4	
65	70	70	62	8	M8x4	
80	70	70	62	8	M8x4	
100	110	90	90	10	M10x4	
125	110	90	90	10	M10x4	standard
150	110	90	90	10	M10x4	
200	175	140	-	17	M16x4	
250	175	140	-	17	M16x4	

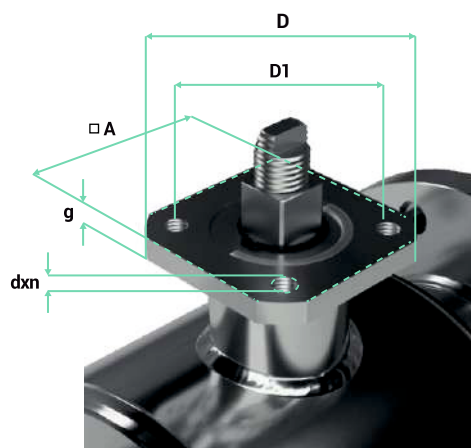

MOMENTY OBROTOWE KURKA

DN	15	20	25	32	40	50	65	80	100	125	150	200	250
Moment obrotowy (Nm)*	10	15	20	25	40	80	100	120	150	190	350	550	800
Maksymalny dopuszczalny moment obrotowy (Nm)**	40		120		140		300		1000	1200		1300	

* zakładany moment obrotowy w warunkach montażu. W celu doboru odpowiedniego siłownika proszę o kontakt z producentem

** następuje uszkodzenie kurka

WYMIARY KOŁNIERZY WG NORMY ASME B16.5

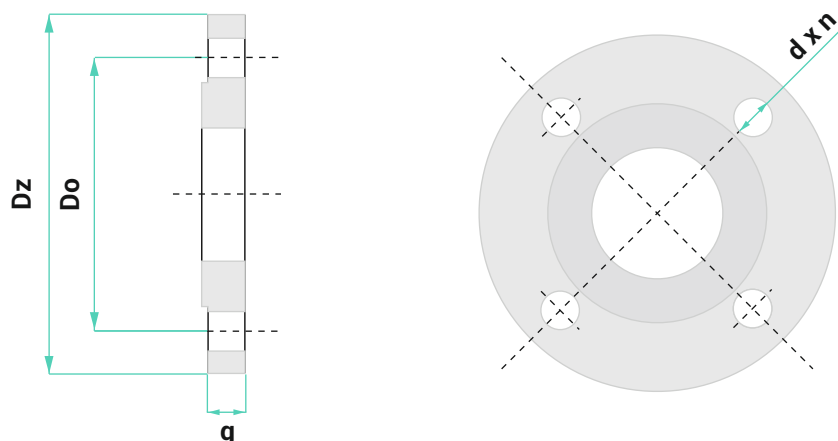

NPS	1/2	3/4	1	1 1/4	1 1/2	2	2 1/2	3	4	5	6	8	10
DN	15	20	25	32	40	50	65	80	100	125	150	200	250

Kołnierze wg ASME B16.5; CLASS 150													
Dz	90	100	110	115	125	150	180	190	230	255	280	345	405
Do	60,3	69,9	79,4	88,9	98,4	120,7	139,7	152,4	190,5	215,9	241,3	298,5	362
dxn	15,9x4	15,9x4	15,9x4	15,9x4	15,9x4	19x4	19x4	19x4	19x8	22,2x8	22,2x8	22,2x8	25,4x12
g	9,6	11,2	12,7	14,3	15,9	17,5	20,7	22,3	22,3	22,3	23,9	27	28,6

Kołnierze wg ASME B16.5; CLASS 300													
Dz	95	115	125	135	155	165	190	210	255	280	320	380	445
Do	66,7	82,6	88,9	98,4	114,3	127	149,2	168,3	200	235	269,9	330,2	387,4
dxn	15,9x4	19x4	19x4	19x4	22,2x4	19x8	22,2x8	22,2x8	22,2x8	22,2x8	22,2x12	25,4x12	28,6x16
g	12,7	14,3	15,9	17,5	19,1	20,7	23,9	27	30,2	33,4	35	39,7	46,1



**Polski producent
kurków kulowych**



Dystrybutor armatury



Brzyście 35 k/Mielca
39-307 Gawłuszowice



Tel: +48 17 785 28 93
Tel: +48 17 785 28 94



biuro@andrex-vg.com
www.andrex-vg.com