

**DP11-21-11 (DP21k)**

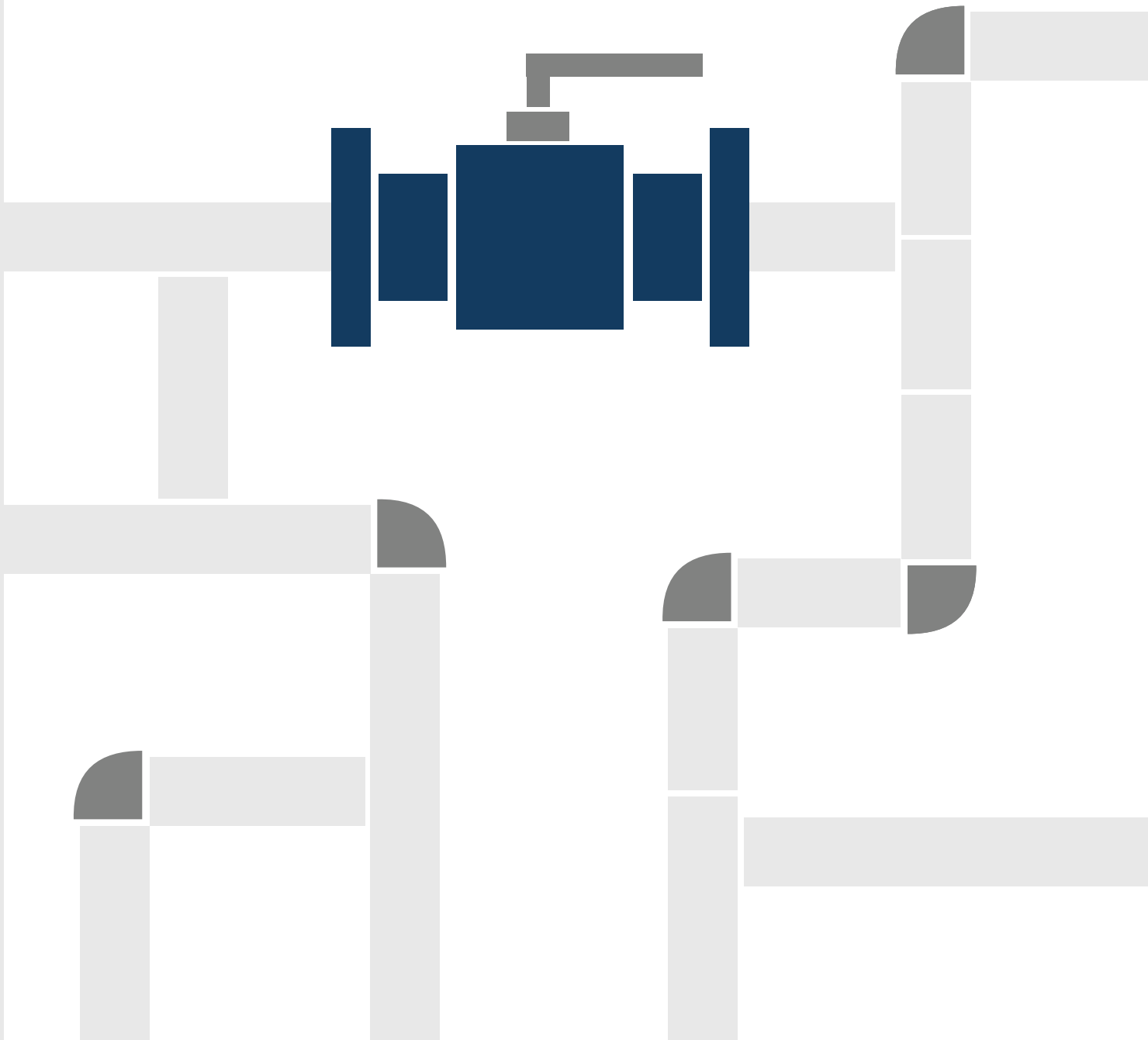

# DP11-21-11 (DP21k)

## FLANGED BALL VALVE WITH FULL BORE - ONE-PIECE



**DIAMETER RANGE**  
DN32 ÷ DN80



**NOMINAL PRESSURE**  
PN16 ÷ PN40



**TEMPERATURE RANGE**  
-50°C ÷ +250°C

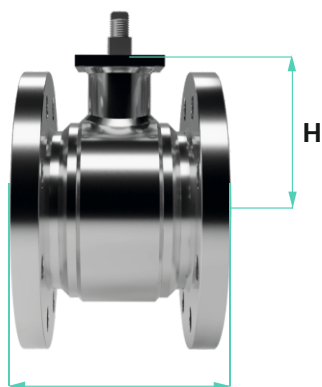

L

DN	32	40	50	65	80
Bore	32	40	50	62	75
L-length	104	106	108	112	140
Series EN558+A1	8	13	13	13	107
Weight (kg)	4,7	5,3	7,5	10,1	14,6
H-height	61	65	91	102	110
Steering	D	D	NP/D	NP/D	NP/D

D - hand lever

NP/D - hand lever or adjustment for actuator assembly

### EXECUTION

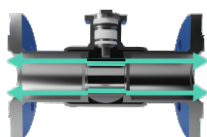

REDUCED BORE

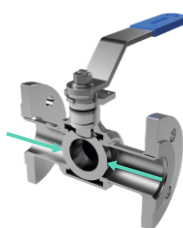

TIGHTNESS CLASS A

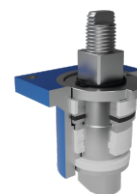

MAINTENANCE-FREE STUFFING BOX

### STEERING



HAND LEVER



MANUAL GEAR



ELECTRIC OR PNEUMATIC ACTUATOR

### OPTION

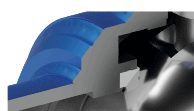

FIRE SAFE  
EN-ISO 10497:2010



TA - LUFT  
PN-EN ISO 15848-1  
VDI 2440

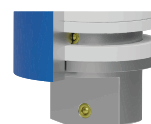

ATEX  
2014/34/UE  
ANTISTATIC

## MATERIAL VERSIONS

Material type	Carbon steel		Stainless alloy steel										Other
	11	12	21	22	23	24	25	26	41	42	43 Duplex	44 Hastelloy	
Mark													
Body	P355/S355	P235/S235	1.4541	1.4301	1.4571	1.4571	1.4571	1.4404	1.4539	1.4931	1.4462	2.4602	according to customer requirements
Connection	P355/S355	P235/S235	1.4541	1.4301	1.4541	1.4571	1.4571	1.4571	1.4539	1.4931	1.4462	2.4602	
Ball	1.4301	1.4301	1.4301	1.4301	1.4301	1.4404	1.4571	1.4404	1.4539	1.4931	1.4462	2.4602	
Stem	1.4305	1.4305	1.4305	1.4305	1.4305	1.4404	1.4571	1.4404	1.4539	1.4931	1.4462	2.4602	
Ball seat	PTFE, PTFE + fiberglass 25%												
Sealing package	PTFE, PTFE + fiberglass 25%												

## BALL VALVES - STEERING - HAND LEVER

DN	W	H1	s	Typ	Function
15	147	48	8 x 8	A	standard
20 - 25 - 32	167	59	10 x 10	A	
40	217	59	10 x 10	A	
50	280	61	17 x 17	A	
65 - 80	360	61	17 x 17	A	
100 - 125	472	23	24 x 24	B	
150	672	23	24 x 24	B	option

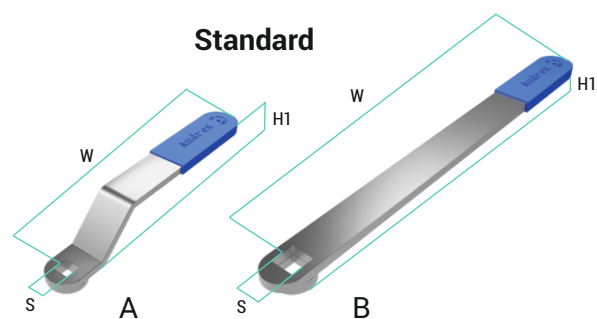

## BALL VALVES - STEERING - STEM EXTENSION

DN	S	a	H standard	Type	H max
15	8 x 8	5	100	KL1 - 100	according to order
20	10 x 10	5	100	KL2 - 100	
25	10 x 10	5	100	KL2 - 100	
32	10 x 10	5	100	KL2 - 100	
40	10 x 10	5	100	KL2 - 100	
50	17 x 17	6	100	KL3 - 100	
65	17 x 17	6	100	KL3 - 100	
80	17 x 17	6	100	KL3 - 100	
100	24 x 24	8	100	KL4 - 100	
125	24 x 24	8	100	KL4 - 100	
150	24 x 24	8	100	KL4 - 100	
200	42 x 42	12	100	KL5 - 100	
250	42 x 42	12	100	KL5 - 100	

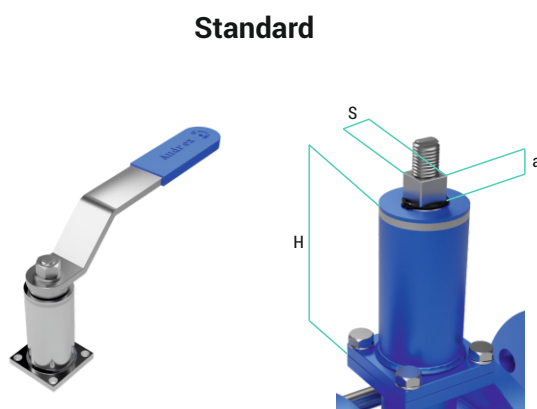

## STEERING OPTIONS



with possibility of using padlock, seal

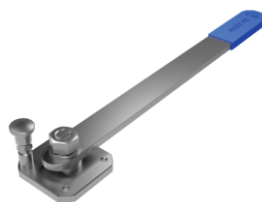

with protection against accidental steering



with limit indicator



with ratchet



stainless steel



shifted horizontally



special execution



spring lever

## BALL VALVE STEERING MANUAL GEAR\*\*



standard



with stem extension



with limit indicator



with chain

## PNEUMATIC ACTUATOR\*\*



## ELECTRIC ACTUATOR\*\*

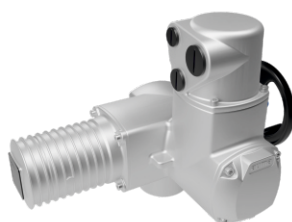

- single acting
- single acting with limit indicator
- single acting with limit indicator and solenoid valve
- double acting with limit indicator
- double acting with limit indicator and solenoid valve
- special execution

\*\* dimensions available on inquiry

## ACTUATOR ADAPTER

DN	d1	d3	S	a	H	Type	H max
15	65	50	14 x 14	14	50	F 05	
20	65	50	14 x 14	15	75	F 05	
25	65	50	14 x 14	15	75	F 05	
32	65	50	14 x 14	15	75	F 05	
40	65	50	14 x 14	15	75	F 05	
50	90	70	17 x 17	18	60	F 07	
65	90	70	17 x 17	18	60	F 07	
80	90	70	17 x 17	18	60	F 07	
100	125	102	22 x 22	25	76	F 10	
125	125	102	22 x 22	25	76	F 10	
150	125	102	22 x 22	25	76	F 10	
200	150	125	27 x 27	30,5	97	F 12	
250	150	125	27 x 27	30,5	97	F 12	

according to order

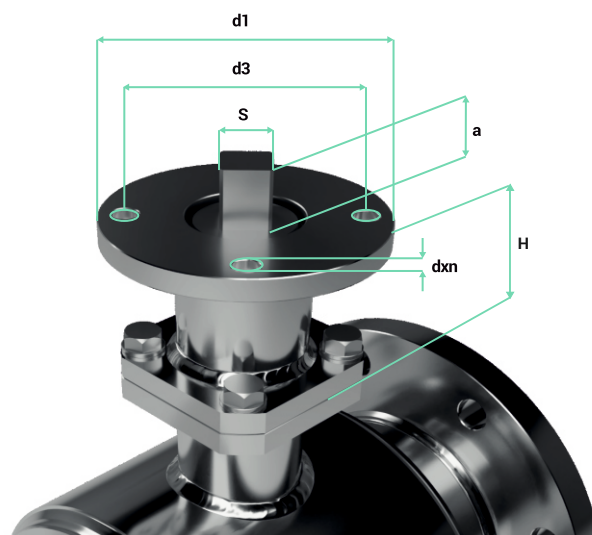

## OPTIONAL EQUIPMENT ADAPTER

DN	D	D1	□ A	g	dxn	Function
15	56	42	50	8	M6x4	
20	65	50	50	8	M6x4	
25	65	50	50	8	M6x4	option
32	65	50	50	8	M6x4	
40	65	50	50	8	M6x4	
50	70	70	62	8	M8x4	standard
65	70	70	62	8	M8x4	
80	70	70	62	8	M8x4	
100	110	90	90	10	M10x4	
125	110	90	90	10	M10x4	
150	110	90	90	10	M10x4	
200	175	140	-	17	M16x4	
250	175	140	-	17	M16x4	

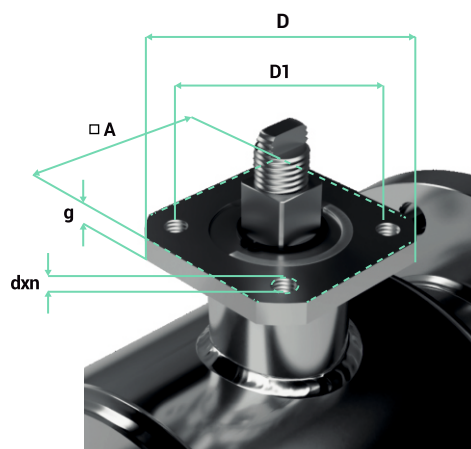

## VALVE TORQUES

DN	15	20	25	32	40	50	65	80	100	125	150	200	250
Torque (Nm)*	10	15	20	25	40	80	100	120	150	190	350	550	800
Maximal allowable torque (Nm)**	40		120		140		300		1000	1200	1300		

\* Torque established during assembly. In order to match the actuator properly, please contact the manufacturer

\*\* Valve damage occurs

## FLANGE DIMENSIONS ACCORDING TO PN-EN 1092-1

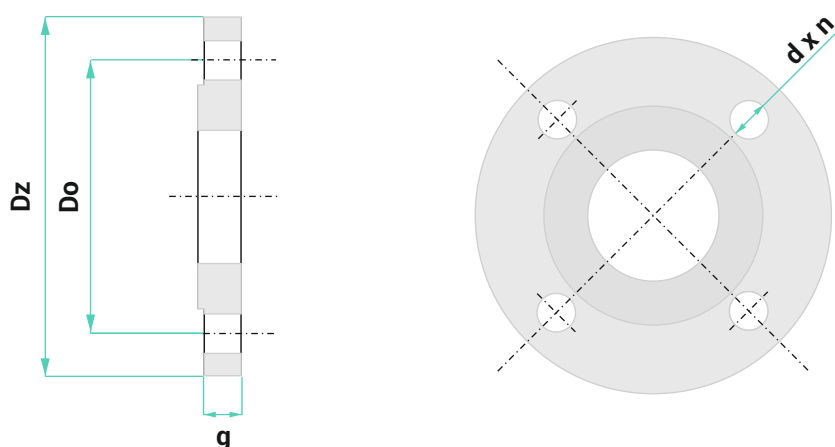

DN	10	15	20	25	32	40	50	65	80	100	125	150	200	250	300
<b>Flanges according to PN-EN 1092-1; PN 6</b>															
Dz	75	80	90	100	120	130	140	160	190	210	240	265	320	375	440
Do	50	55	65	75	90	100	110	130	150	170	200	225	280	335	395
dxn	11 x 4	11 x 4	11 x 4	11 x 4	14 x 4	14 x 4	14 x 4	14 x 4	18 x 4	18 x 4	18 x 8	18 x 8	18 x 8	18 x 12	22 x 12
g	12	12	14	14	16	16	16	16	18	18	20	20	22	24	24
<b>Flanges according to PN-EN 1092-1; PN 10</b>															
Dz	90	95	105	115	140	150	165	185	200	220	250	285	340	395	445
Do	60	65	75	85	100	110	125	145	160	180	210	240	295	350	400
dxn	14 x 4	14 x 4	14 x 4	14 x 4	18 x 4	18 x 4	18 x 4	18 x 8	18 x 8	18 x 8	18 x 8	22 x 8	22 x 8	22 x 12	22 x 12
g	14	14	16	16	18	18	20	20	20	22	22	24	24	26	26
<b>Flanges according to PN-EN 1092-1; PN 16</b>															
Dz	90	95	105	115	140	150	165	185	200	220	250	285	340	405	460
Do	60	65	75	85	100	110	125	145	160	180	210	240	295	355	410
dxn	14 x 4	14 x 4	14 x 4	14 x 4	18 x 4	18 x 4	18 x 4	18 x 8	18 x 8	18 x 8	18 x 8	22 x 8	22 x 12	26 x 12	26 x 12
g	14	14	16	16	18	18	20	20	20	22	22	24	26	29	32
<b>Flanges according to PN-EN 1092-1; PN 25</b>															
Dz	90	95	105	115	140	150	165	185	200	235	270	300	360	425	485
Do	60	65	75	85	100	110	125	145	160	190	220	250	310	370	430
dxn	14 x 4	14 x 4	14 x 4	14 x 4	18 x 4	18 x 4	18 x 4	18 x 8	18 x 8	22 x 8	26 x 8	26 x 8	26 x 12	30 x 12	30 x 16
g	14	14	16	16	18	18	20	22	24	26	28	30	32	35	38
<b>Flanges according to PN-EN 1092-1; PN 40</b>															
Dz	90	95	105	115	140	150	165	185	200	235	270	300	375	450	515
Do	60	65	75	85	100	110	125	145	160	190	220	250	320	385	450
dxn	14 x 4	14 x 4	14 x 4	14 x 4	18 x 4	18 x 4	18 x 4	18 x 8	18 x 8	22 x 8	26 x 8	26 x 8	30 x 12	33 x 12	33 x 16
g	14	14	16	16	18	18	20	22	24	26	28	30	36	42	52
<b>Flanges according to PN-EN 1092-1; PN 63</b>															
Dz	100	105	130	140	155	170	180	205	215	250	295	345	415	470	530
Do	70	75	90	100	110	125	135	160	170	200	240	280	345	400	460
dxn	14 x 4	14 x 4	18 x 4	18 x 4	22 x 4	22 x 4	22 x 4	22 x 8	22 x 8	26 x 8	30 x 8	33 x 8	36 x 12	36 x 12	36 x 16
g	20	20	22	24	24	26	26	26	30	32	34	36	48	55	65
<b>Flanges according to PN-EN 1092-1; PN 100</b>															
Dz	100	105	130	140	155	170	195	220	230	265	315	355	430	505	585
Do	70	75	90	100	110	125	145	170	180	210	250	290	360	430	500
dxn	14 x 4	14 x 4	18 x 4	18 x 4	22 x 4	22 x 4	26 x 4	26 x 8	26 x 8	30 x 8	33 x 8	33 x 12	36 x 12	39 x 12	42 x 16
g	20	20	22	24	24	26	28	30	34	36	42	48	60	72	84

Possibility of producing CLASS 150÷600



**Polish manufacturer  
of ball valves**



**Fittings distributor**



Brzyście 35 near Mielec  
39-307 Gawłuszowice



Tel: +48 17 785 28 93  
Tel: +48 17 785 28 94



biuro@andrex-vg.com  
www.andrex-vg.com