

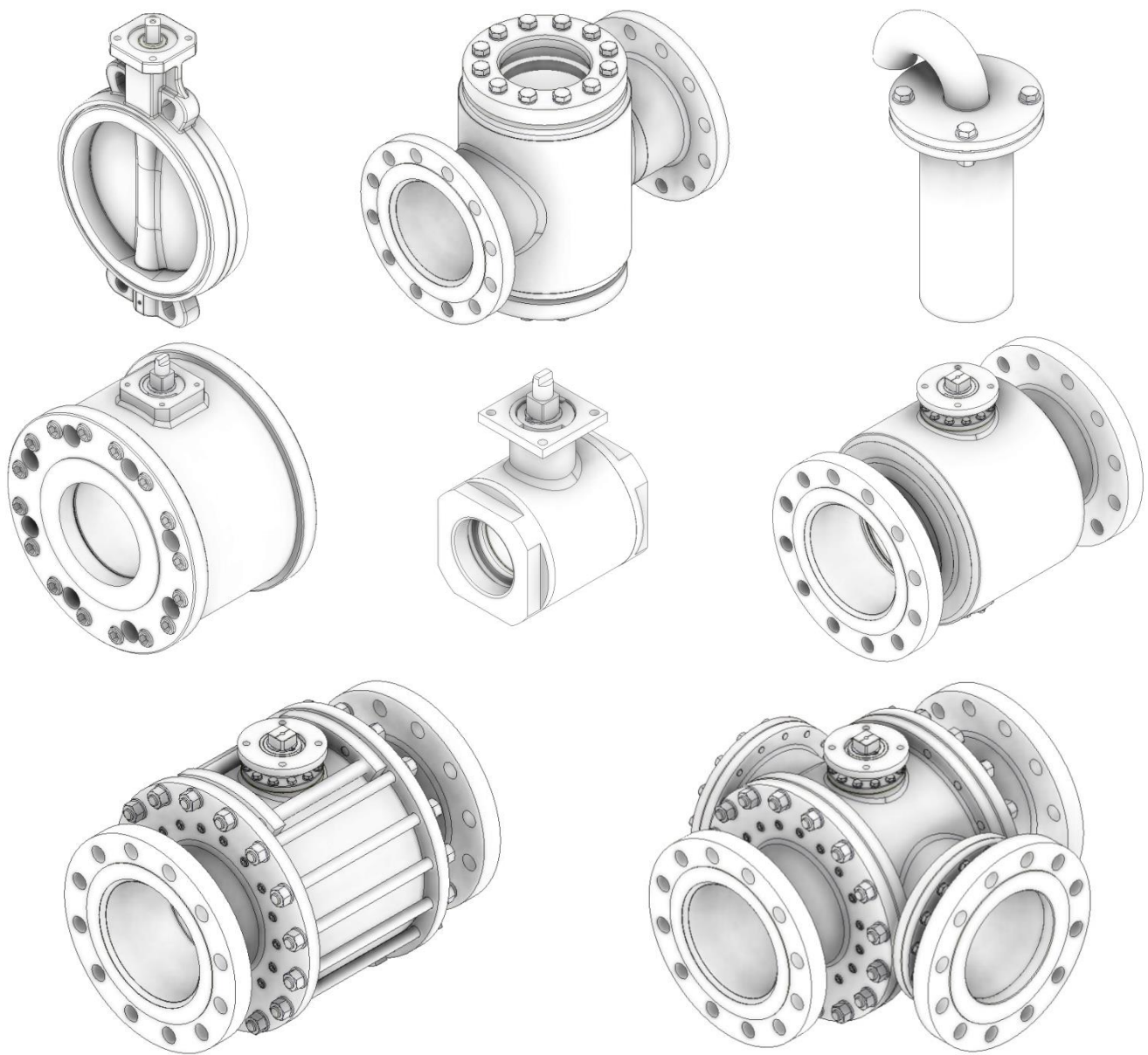

## Service manual for 3way ball valve DP55



## Contents

1. General information	
1.1 Applied symbols .....	4
1.2 Manula range.....	5
1.3 Control during delivery.....	5
1.4 Complaints.....	5
1.5 Guarantee.....	5
2. Safety.....	6
2.1 People protection .....	6
2.1.1 Safety guideline regardingd assembly.....	6
2.1.2 Safety guideline regarding set-up / start-up.....	7
2.1.3 Safety guideline regarding maintenance / repair .....	8
2.2 Device safety .....	9
3. Name plate .....	11
4. Ball valves .....	12
4.1 Application and operation .....	12
4.2 Storage.....	14
5. Assembling .....	14
5.1 Assembling of flanged ball valves.....	15
5.2 Assembling of butt welded ball valves .....	18
5.3 Assembling of threaded ball valves.....	19
6. Gland packing box .....	21
6.1 Building of gland packing box.....	21
6.2 Replacement of sealing .....	23
7. Change of steering devices.....	26
7.1 Disassembly of steering hand lever.....	26
7.2 Assembling of column .....	27
7.3 Assembling of actuator mounting.....	28
7.4 Lever with return spring .....	29
8. Options of ball setting in multiway valves .....	31
9. Maximum static torque in ball valves .....	34

## Dear Client

Most of all this manual is dedicated for assemblers and users of valves and fittings. At the same time the presented instruction can be helpful for engineers and designers, people making completion of valves and fittings and responsible for supervision of operation.

Our products are designed according to actual state of technical knowledge and according to recognised principals of safety. Nevertheless it can happen during operation hazards for health and life of users and third persons. It can also happen defects of machines and other permanent assets. The post can be only operated by trained personnel in the subjective scope, exclusively according to purpose. Not following of safety guidelines implies loss for any damage claims.



**We ask to get familiar with this manual carefully and following especially guidelines and warnings. Instruction should be diligently stored for case of any questions.**

In case of any inquiries regarding valves and fittings we are at your disposal



### NORTH AREA

**Karol Szpankiewicz**

Regional Manager for Key Clients

mobile 667 661 498

[kszpankiewicz@andrex-vg.com](mailto:kszpankiewicz@andrex-vg.com)

### SOUTH AREA

**Patryk Puchala**

Regional Manager for Key Clients

mobile 698 609-792

[ppuchala@andrex-vg.com](mailto:ppuchala@andrex-vg.com)

## 1. General information

The presented documentation includes important information, guidelines and warnings indispensable for faultless service and operation on all stages. Documentation does not take into account local regulations which obligation of observance is up to user.

Before start-up of device you shall get familiar with the contents of the subjective manual and you shall follow its recommendations. User shall determine on own behalf the range of responsibility, competences and personnel supervision. Especially user is obliged to get assured that personnel responsible for all activities connected with device of valves and fittings has understood the contents of the subjective manual. This document is inseparable part of valves and fittings and shall be stored in place accessible for operational personnel. In case of damage or loss of the document, the user shall take actions in order to get new copy.

### 1.1 Applied symbols



Texts marked with this symbol include very important guidelines, among others in order not to enable dangers for health threats. It is necessary to follow the presented text.



Texts marked with this symbol include very important guidelines, among others also in order not to enable for material damage. It is necessary to follow the presented text.



This symbol means danger of electric shock. In case of not keeping proper caution exists danger of body injury and danger to life.



Ten symbol oznacza niebezpieczeństwo oparzenia. W przypadku braku zachowania odpowiedniej ostrożności istnieje niebezpieczeństwo uszkodzenia ciała.



This symbol means texts including comments, guidelines and advices.



This symbol means description of activities which need to be done by client.

## 1.2 Manual range

Manual regards assembly and service of standard version of valves and fittings, its varieties and valves and fittings integrated with automation components.

## 1.3 Control during delivery

Directly with delivery shall be controlled valves and fittings in terms of possible transportation damages and defects. Quantity and kind of valves and fittings can be easily checked on basis of enclosed delivery document.

## 1.4 Complaints

**Damage claims regarding transportation damages can be claimed only after immediate appeal to forwarder.**

For return shipment (transportation damage / repair) shall be prepared protocol of complaint and sent to production facility, to the extent possible in original packing.

For return shipment shall be enclosed following information:

- Name and address of receiver,
- Number of valves and fittings/ number of order /number of part,
- Fault description.

## 1.5 Guarantee

For valves and fittings we grant guarantee according to purchase / sales agreement. The documents which enables to start guarantee procedure is application to the producer describing the faults of valves and fittings. The print application of valves and fittings fault you can easily find in the appendix No 1 of this manual.

## 2. Safety

Depending on technical conditions and moment of assembly, set-up and start-up of valves and fittings shall have regard to specific aspects of safety.

In case if for example valves and fittings are assembled in ready fo operation chemical device, safety aspects by start-up have quite different meaning, than it would be start-up for tests purposes in "dry" part of device in assembly hall.

We cannot know all circumstances of moment of assembly / set-up / start-up, therefore in the below descriptions we put guidelines about safety which cannot regard specific device.

You shall follow (only) to guidelines regarding the specific situation !

### 2.1 People protection

#### 2.1.1 Safety guidelines regarding assembly



We pay much attention that assembly, pneumatic installation (in case of accessories also electrical) and set-up of valves and fittings can be made only by qualified specialists with thorough mechanical (and electrical) knowledge.



To get assure that after assembly in machine / device valves and fittings follow requirements of machine directive.



To switch off all connected with assembly or repair machines / devices. In case of necessity to switch it off from eletric power supply.



To check (e.g. in case of mechanical devices), if switching off machine / device will not cause dangers.



If necessary in case of breakdown of valves and fittings in working machine you shall immediatly inform about it the shift manager / engineer responsible for safety or manager of plant in order to prevent leakage of chemicals or gas with help of appropriate measures.



Before assembly or repair, remove pressure from machine / pneumatic / hydraulic devices .



In case of necessity put warning plates in order not to cause accidental start-up of machine / device.



Assembly / repair shall be made with preserving being in force safety and hygienic and safety work regulations.



To control safety device (e.g. emergency switch offs, safety valves etc.) taking into account its proper working.

### 2.1.2 Safety guidelines regarding set-up / start-up



As result of (pneumatic, electrical or manual) start-up of valves and fittings can be enabled or disabled flow of gases, vapours, liquids etc.. To get assure that as result of start-up or tests set-up will not appear dangers for people or environment.



In case of necessity put warning plates in order not to cause accidental start-up or switch off from operation of machine / device.



After completion of set-up to check correct operation and possibly keeping of required angle by valves and fittings.



To check operation of limit switches (option).



To check if main operation unit is 100% closed, if steering controller signalizes achieving end position (option).



With help of appropriate measures not to let to jam of arms by mobile setting sections.



To control safety device (e.g. limit switches, safety valves etc) taking into account proper operation.



Start-up or set-up to execute only according to instructions described in this manual.



During setting of ongoing (ready for work) valves and fittings with options (e.g. turn gear, solenoid valve, limit switches) there is danger of touching elements under voltage. Therefore the set-ups can be executed only by electrician or person with adequate education / knowledge, aware of potential dangers.

### 2.1.3 Safety guidelines regarding maintenance / repair



It is forbidden to execute maintenance / repair of valves and fittings under pressure.

Before assembly of valves and fittings should be explained a few important points:

- If disassembled valves and fittings will be immediately replaced by new one ?
- If eventually should be stopped production on installation ?
- If before disassembly shall be informed particular persons? etc.



In case of necessity immediately inform about maintenance / repair the shift manager / engineer responsible for safety or manager of plant in order to prevent leakage of chemicals or gas with help of appropriate measures.



Valves and fittings can contain in the spigot (e.g. ball valves) medium under pressure. To drop off pressure from pipe installation with assembled valves and fittings in order to remove residual pressure.



To switch off steering pressure, steering voltage and/or current supply.



In case of necessity put warning plates.

\* in order to disable accidental start-up of disassembled part of machine/device

\* in order to disable to switch on steering pressure, current supply and voltage of steering of optional actuators and accessories.



In case of breakdown of valves and fittings to contact with the producer. The phone number was given on the first pages of this manual.



After ascertainment of damage of valves and fittings to switch off all machines / devices affected by this damage. Necessarily follow safety guidelines.



Not to assembly, start-up or change set-up of valves and fittings in case of damage of valves and fittings, supply wires or eventually connected on flanges actuators.



After ending of maintenance / repair to check valves and fittings taking into account the proper operation and connection of conduits having on mind the tightness.



Eventually to check operation of assembled optional accessories, e.g. turn gears, limit switches etc..

## 2.2 Device safety

Valves and fittings:

- It is quality product, manufactured according to recognised engineering principals,
- has left the production facility in the perfect safety state.



In order to keep this state assembler / user shall execute skillfully and with highest precision own tasks according to descriptions in this manual.

We assume that user is qualified specialist or has thorough mechanical and electrical knowledge in range of valves and fittings.



To assure that valves and fittings are used only in admissible limits (see Technical data).



Valves and fittings can be used only for purposes according to its instruction.



Valves and fittings can be used only according to parameters determined in technical data.



It is forbidden to unscrew, remove bonnets or assembled accessories if valves and fittings are under pressure.



Not to assembly, start-up or change set-up of valves and fittings in case of damage of valves and fittings, supply wires or eventually connected on flanges actuators.



After ending of maintenance / repair to check valves and fittings taking into account the proper operation and connection of conduits having on mind the tightness.



Eventually to check operation of assembled optional accessories, e.g. turn gears, limit switches etc..

Usage of valves and fittings beyond admissible temperature range can cause overload and damage of gaskets or bearings. Usage of actuator above maximum working pressure can cause damage of interior components or housing. The given values are based on the experiences and describe normal quality of product. They are serving for evaluation of general availability, but at the same time the company ANDREX cannot assure suitability of product.

The duty of user in area of constructive responsibility is to confirm suitability of product, which faultless quality we guarantee on basis of our delivery and payment conditions, in particular case and determination of its service.

### 3. Name plate

Unambiguous identification of valves and fittings enables name plate which gives the most important technical data according to PN-EN 19:2005.



Change / remove of technical data placed on name plate is strictly forbidden.



Drawing 1 – Name plate

On the name plate are stamped main parameters as well as adequate marking of valves and fittings. The description of separate fields has been presented in table below.

<b>DN</b>	Nominal diameter of valves and fittings passage.
<b>TS</b>	Maximum temperature range of valves and fittings in °C.
<b>PN</b>	Maximum admissible working pressure of valves and fittings in bar.
<b>KJ</b>	Confirmation of valves and fittings approval according to standards.
<b>Numer</b>	Identification number of valves and fittings (number / month / year).
<b>Material</b>	Marking of body material of valves and fittings.

Moreover, it is also placed on name plate the commercial name of valves and fittings. In case of loss / damage of name plate you shall immediately contact with manufacturer in order to prepare duplicate. The lack of name plate deprives the user from complaint right as well as purchase order for spare parts for valves nad fittings.

## 4. Ball valves

### 4.1 Application and operation

Three-way ball valve, demountable, produced in two versions: with an L-type ball - a ball at an angle of 90°, with a T-type ball - a ball with three holes. It is used to cut off the flow of the working medium in heating systems, industrial and gas installations, tanks or cisterns and to control the flow direction of given medium. In order to secure faultless work of ball valve, flowing medium shall be clean without any impurities and fulfill working parameters according to marking on the name plate. Not following of above mentioned conditions can cause damage of interior parts in valve, especially sealings of ball.

Water quality used in closed heating systems and central heating networks needs to fulfill requirements of standard PN-85/C-04601 „Water for energetic purposes. Requirements and testing of water quality”.



Not put into ball valve hands and other things. Result of not following this remark can be permanent personal injury and in some cases even death. Absolutely follow safety guideline.

In most cases, a hand lever placed on the valve or optionally selected actuator is responsible for the appropriate control of the ball valve. The control is carried out by turning the lever (actuator) on the stem, which directly cooperates with the ball. The stem is sealed with seals made of appropriately selected materials in accordance with the specific operating conditions of valve and parameters of medium. The rotation limiter guarantees the correct positioning of the ball in appropriate positions.



Ball valve shall work only in position „fully closed” or „fully open”.

The current position of the ball setting in the ball valve is determined by the milling at the end of the stem. Below is the initial setting for the ball valve for the 2L-90 variant and after turning it by 90° clockwise, assuming that the third way is directed downwards as in the picture below.

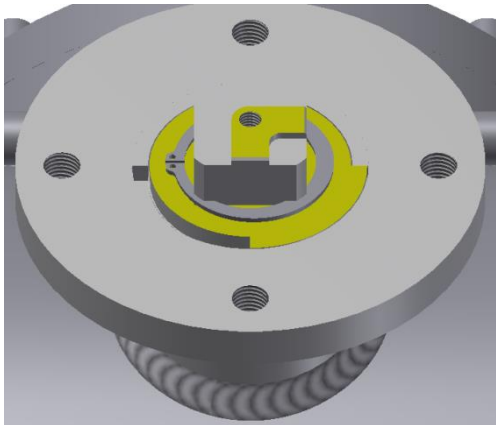
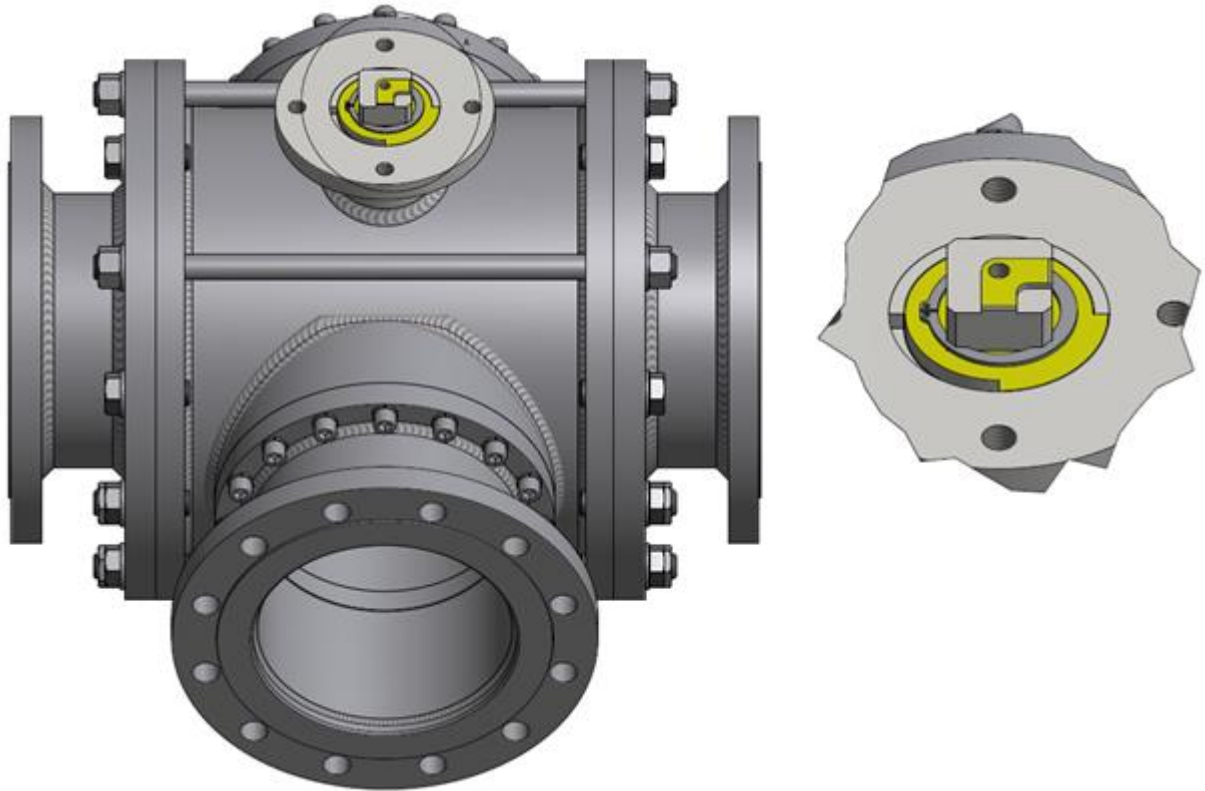

Starting position: setting 2L-90

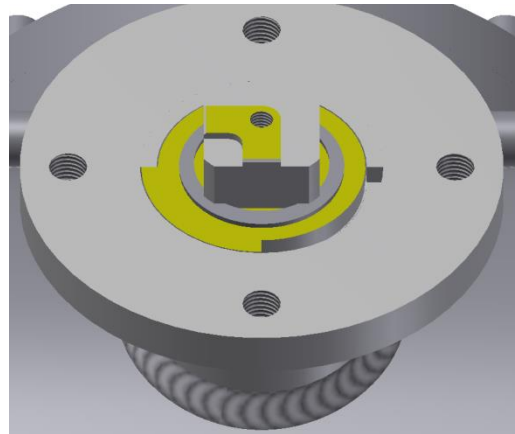

90° overdrive position: 2L-90 setting

When attaching the device for steering, always angularly set it in accordance with the marking on stem. Removal of the steering device on running valve is permitted provided the valve is in the "fully open" or "fully closed" position and extreme care must be taken.



This manual is not an instruction for making repairs that require specialist knowledge and equipment. For major repairs and overhauls, the valve manufacturer is available.



**It is strictly forbidden to unscrew the nuts on the screws tightening the body with the connections.**

## 4.2 Storage

Ball valves should be stored in dry rooms and protected against weather and corrosive factors. The connections of the ball valves should be plugged. Unpainted surfaces should be preserved with anti-corrosion grease. Ball valves should be stored in a stable position. Ball position always in "fully open" position.

## 5.Assembling



Before installing, maintaining, adjusting, operating or starting the ball valve, read the "Safety" section thoroughly.



Before installing the ball valve, check its name plate for compliance with the documentation.

In order for the valve to be properly installed and to achieve tightness with the seals, proper assembly is necessary. The assembly process depends on many factors, but the most important thing is to maintain consequences of action.

In the case of installation of valves with actuators or gears, the valves must be installed in a horizontal position. The actuator must be positioned vertically in relation to the ball valve and the pipeline.

If the valve is installed in a different position, it must be absolutely ensured that there are no contraindications to its operation in a given position. This information can be obtained directly from the manufacturer of the actuator or gearbox and from the supplier of the entire set.

## 5.1 Assembling of flanged ball valves

Preparation of the ball valve for installation consists in:



The ball valve should only be mounted in the "fully open" position.



Dismantle all transport protection and packaging remains. Check the cleanliness of the inside of the ball valve and make sure there are no objects inside.



Before installing the valve, thoroughly clean the inside of the pipeline. Unauthorized impurities may adversely affect the operational safety and service life of the ball valve.



Remove the preservative grease from the sealing surfaces of the flanges on the ball valve and clean the flange on the pipeline.

Appropriate tools are required for cleaning the flange and tightening the screws. In special cases, it can be messy work. Therefore, you should also prepare appropriate clothing (protective clothing if necessary), a helmet, safety glasses, gloves and, most importantly, a safe approach to assembly.

In order to ensure the proper quality of the connection between the valve and the flange, all stressed surfaces should be cleaned. Screws and nuts should be cleaned with a wire brush (optimally brass) to remove dirt from the threads. In flanges, clean the gasket seat surfaces with a suitable tool (preferably with an alloy-based stainless steel bristle wire brush) always brushing in the direction of the grooves.

After cleaning the individual parts, visually inspect each one to eliminate any major defect. Do not install a gasket with observed defects.

Bolted connections should be lubricated with appropriate lubricants to reduce friction in the connection. When selecting a lubricant, ensure that the operating temperature of the lubricant is within the operating temperature limits of the process. Lubricate the threads of the screws and the supporting surfaces, e.g. under the heads of the screws, nuts and washers. Make sure that the grease does not have any lumps and does not contaminate the surface.



Always use torque wrenches or other tools to control tension.

The sequence of tightening the threaded bolts has a major impact on the pressure distribution on the gasket. Improper bolting can cause the flange to move out of parallel setting.

Nuts and bolts and washers must be put in place by hand. The connection should be screwed in accordance with the counter-bolt pattern for the given type of flange.

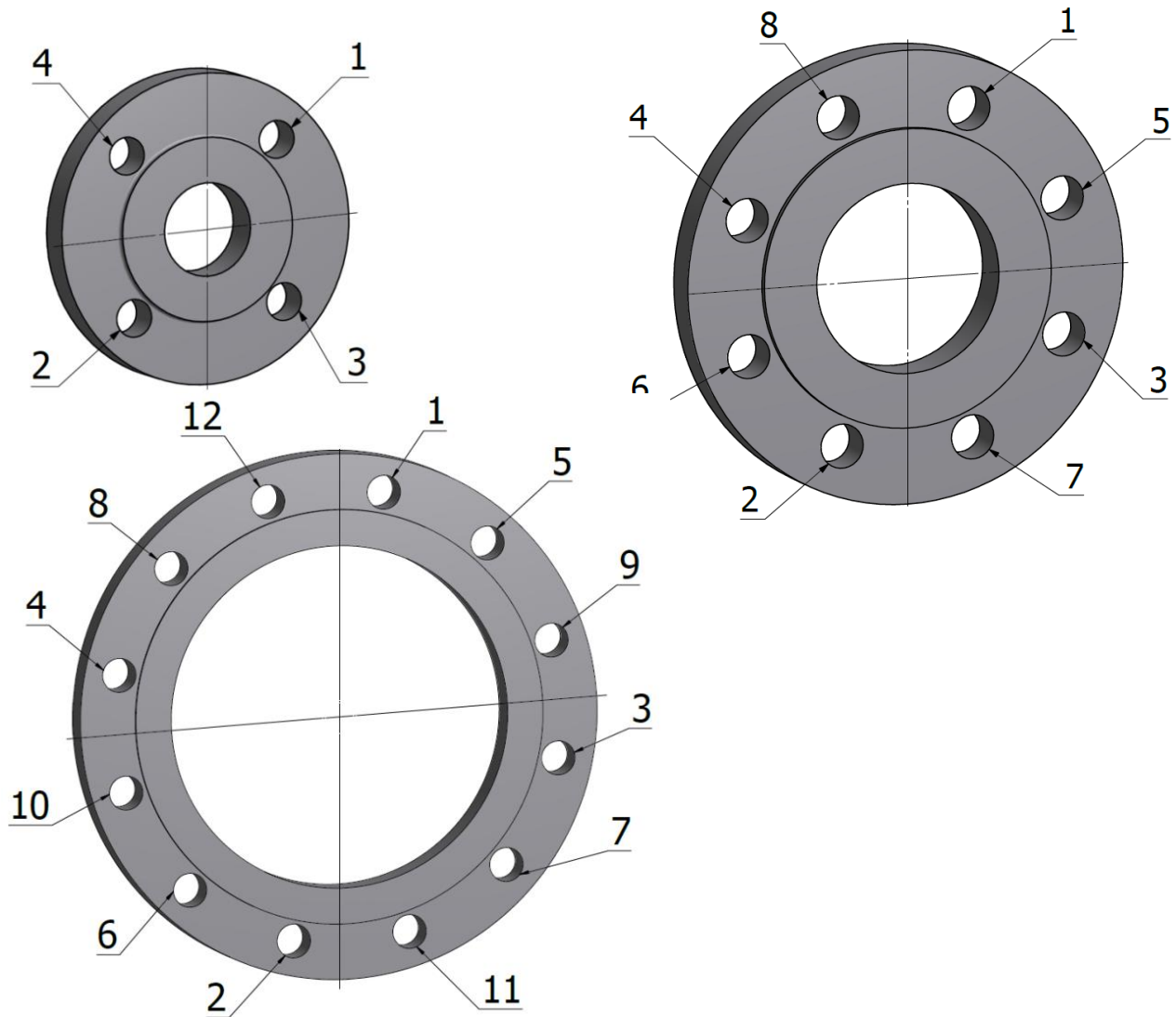

Drawing 4 The sequence of tightening the bolts in the flanges



Any damage to the ball valve connection and errors in the alignment of the pipeline, which may significantly affect the assembly process by increasing stresses, are not allowed.



Loosely pre-tighten the flange nuts by hand.



Using a torque wrench, tighten the nuts to a torque of no more than 30% of the maximum value. Check the condition and position of the wafer gasket.



Using a torque wrench, tighten the nuts to a torque of no more than 60% of the maximum value. Check the condition and position of the wafer gasket.



Tighten the nuts to full torque following the counter bolt pattern.



As a precaution, try to tighten the adjacent nuts until it is determined that no further rotation of any of the nuts is possible.

Ball valves can be mounted on horizontal and vertical pipelines in any position. The flow direction of the medium is free.

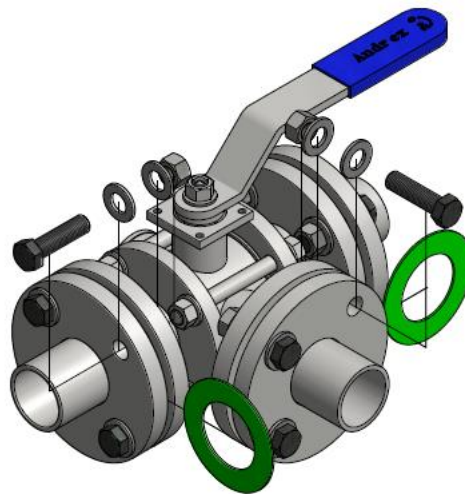

Drawing 5 Flanged valve assembly with hex bolts

## 5.2 Assembling of butt welded ball valves

When assembling the welded ball valves, it is necessary to adapt to the appropriate technology developed by the installation contractor, while maintaining the conditions specified in the PN-EN 13480 - 1:2005 standard. When welding the valve to the installation, pay special attention to the overheating zone in the area of the ball seals - in this case, the valve body should be periodically cooled during welding. The lever can only be turned when the ball valve is completely cooled down.

Only welders who have the appropriate qualifications to weld pipes confirmed by valid certificates (certificates) of the welder's exam may be admitted to perform welding works on gas pipelines and gas equipment. All welds in welded joints should be made as butt welds.

If it is not possible to perform a butt weld, it is allowed to perform a different type of weld after agreeing each time the technology of its implementation with the appropriate organizational unit of the branch.

Proper preparation of the elements and their correct tacking is essential for the quality of the welded joint. When preparing the material for welding, special attention should be paid to thorough cleaning of the welded elements. Elements contaminated in the place of making welds, rust, scale, fats, paints, etc. contribute to the formation of defects in the weld such as pores, blisters and sticking of welds.



**These impurities react with the molten metal during the welding process, which can lead to its oxidation or hydrogenation. The edges of the joined elements must be thoroughly cleaned of these impurities.**

In order to prepare a suitable surface for welding, clean the surfaces with a width of approx. 10-25 mm manually or mechanically, e.g. with a wire brush, sandpaper or angle grinder, or chemically, e.g. by degreasing with acetone or extraction gasoline.



**Any impurities of the material must be removed, as during welding they give off large amounts of gases and oxides and cause bubbles or oxide inclusions in the weld.**



Any damage to the ball valve connection and errors in the alignment of the pipeline, which may significantly affect the assembly process by increasing stresses, are not allowed.



Valves with welding connections should be installed according to the technology developed by the contractor of the installation, observing the specified conditions according to the PN-EN 13480-4:2012 standard.



The assembly method should not cause bending moments on the valve body. Before installation, make sure of the working parameters and nominal dimensions of the pipeline and valve.



**Welding safety requirements apply to the location and environment of the welded joint. There is a possibility of burns. You should be particularly careful.**



When welding the valve to the installation, pay special attention to the overheating zone in the area of the ball seals - in this case, the valve body should be periodically cooled during welding.



**The lever can be turned only after the ball valve has been cooled down completely.**

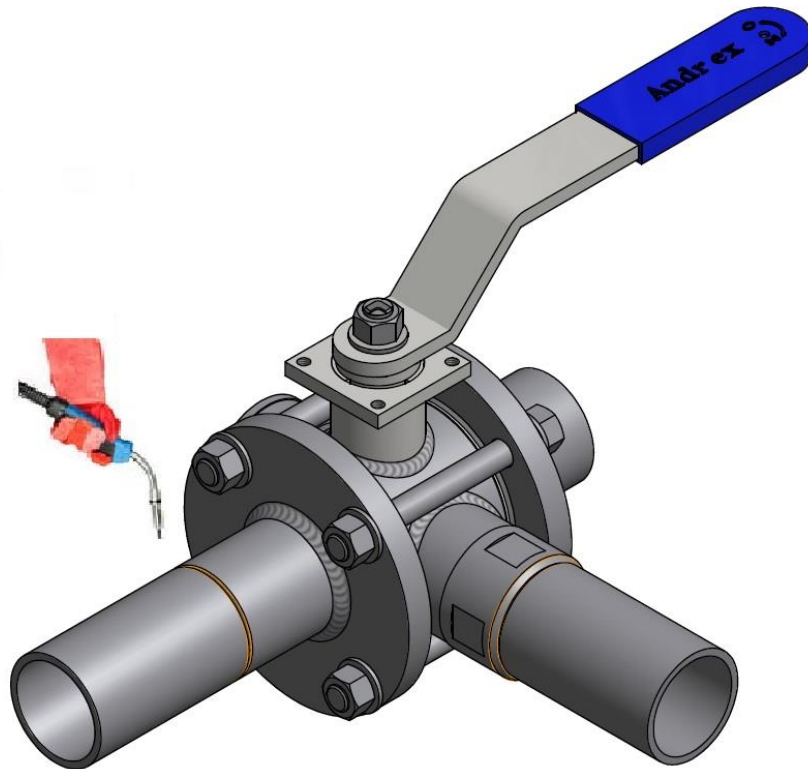

Drawing 6 Installation of the valve for welding

### 5.3 Assembling of threaded ball valves

Incorrect assembly increases the risk of uncontrolled leakage, reducing the pressure resistance of the valve and reducing the service life of the connection. In extreme cases, a bad connection can be damaged. After each disassembly of a threaded connection, reassembly should be carried out using the same force as during the first assembly. Changing the tightening force may result in leakage

and reduce the vibration resistance of the connection by using less force when tightening, or reduce the possibility of reassembly by applying too much force to tighten the connection.

If it is necessary to dismantle the threaded ball valve for transport and reassembly, make sure that no dirt gets into the valve, that the threads and sealing surfaces are not damaged. It is recommended to use protective caps.



When assembling a threaded ball valve, it is absolutely necessary to check whether the ball valve can be loosely screwed to the pipeline, which means that there is no initial stress in the pipeline, and to check the correctness of the thread.



Install appropriate seals at the ends of the pipeline or, in the case of sealing tape (hemp), pay attention to the screwing direction. Use only recommended seals for this type of connection.



Screw the tap onto the stationary pipeline as far as it will go, and then tighten it to obtain tightness by increasing the torque and set the ball valve in the position in accordance with the guidelines. Under no circumstances should you use the steering element of ball valve as a lever.



Install appropriate seals on the other end of the ball valve or pipe. In the case of sealing tape (hemp), pay attention to the direction of screwing. Use only recommended seals for this type of connection.



Screw the second part of the pipeline onto the threaded connection in the ball valve, paying particular attention that the ball valve remains in the initial position. Under no circumstances should you use the steering element of ball valve as a lever.



Check the connections for tightness only after the sealing material used has hardened sufficiently.

In the case of installation of valves with actuator or gears, the valves must be installed in a horizontal position. The actuator must be positioned vertically in relation to the ball valve and the pipeline.

If the valve is installed in a different position, it must be absolutely ensured that there are no contraindications to its operation in a given position. This information can be obtained directly from

the manufacturer of the actuator or gearbox and from the supplier of the entire set.

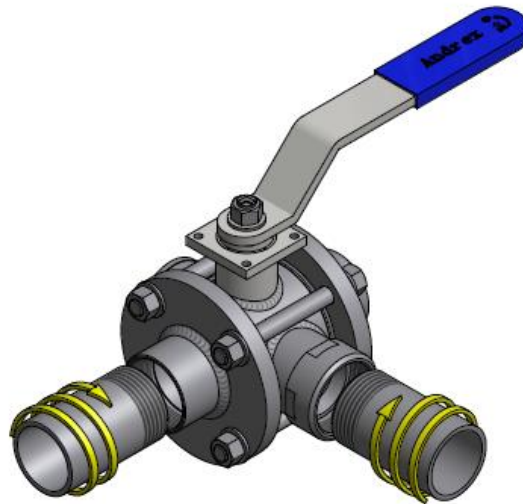

Drawing 7 Internally threaded valve assembly.



Drawing 8 Externally threaded valve assembly.

## 6.Gland packing box

### 6.1 Building of gland packing box

All ball valves produced by us have, among other things, the possibility of sealing. The installed hand lever complicates this operation a bit, but after its disassembly, sealing takes up to 5 minutes.

Stuffing boxes of the new design work perfectly, which is why they received the name maintenance-free and were introduced as a standard to all valves DN50-DN250.

Between the tightness zones II and III, according to drawing 9, there are disc springs that improve the elasticity of the sealing package in zone II and the stabilization system in zone III. This improves resistance to temperature and pressure spikes and compensates for seal wear. The stuffing box in this version makes it possible to mount many types of sealing packages with different operating characteristics. Examples are shown in drawing 10.

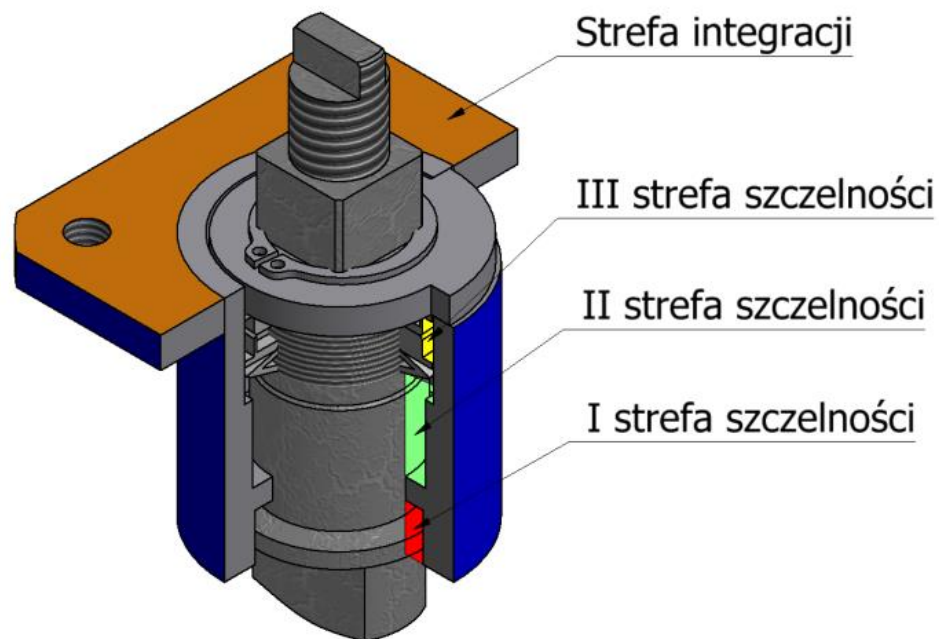

Drawing 9 gland packing box building.

Strefa integracji – Integration zone

III strefa szczelności -third zone of sealing

II strefa szczelności -second tightness zone

I strefa szczelności - first tightness zone

Stuffing boxes have the option of tightening, but this is a rather unused option. Tightening of the stuffing box is dedicated in principle only in extreme operating conditions or in the need to change the characteristics of the sealing.

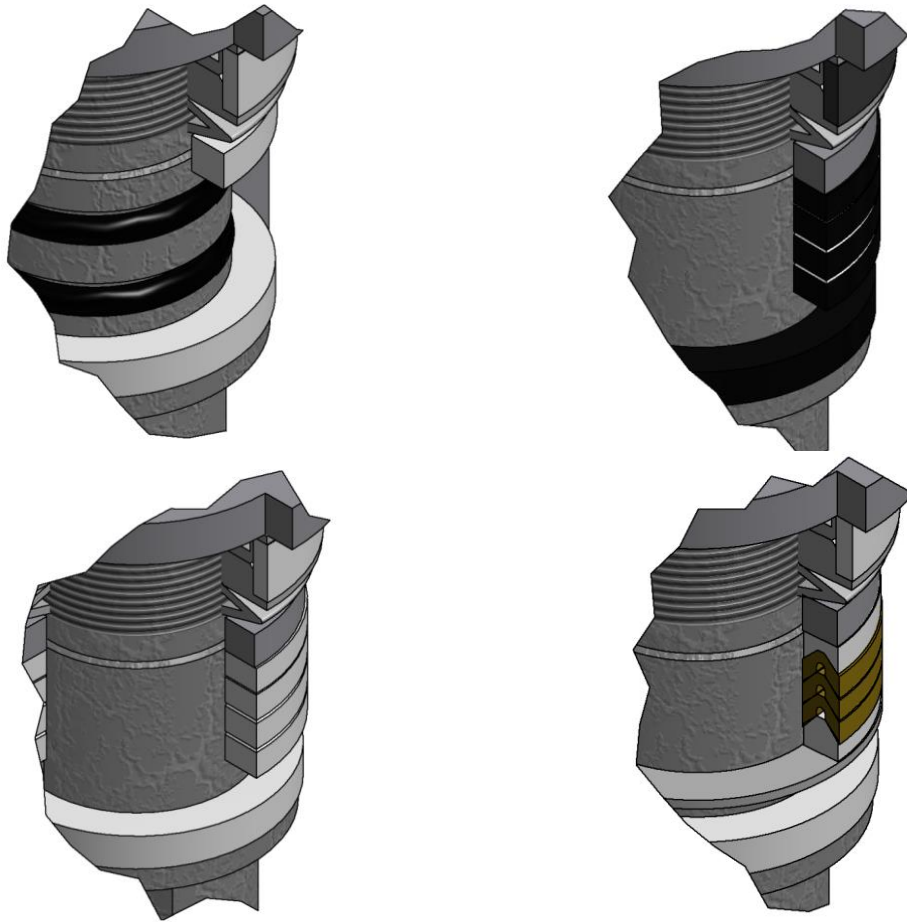

Drawing 10 Example of replaceable sealing in stuffing box.

## 6.2 Replacement of sealing

In order to replace the sealing, if necessary, to another sealing package, be especially careful and follow the health and safety regulations. The diagram in drawing 11 shows in details the various operations in sealing replacement.



**The sealing can only be replaced by the authorized service center.**

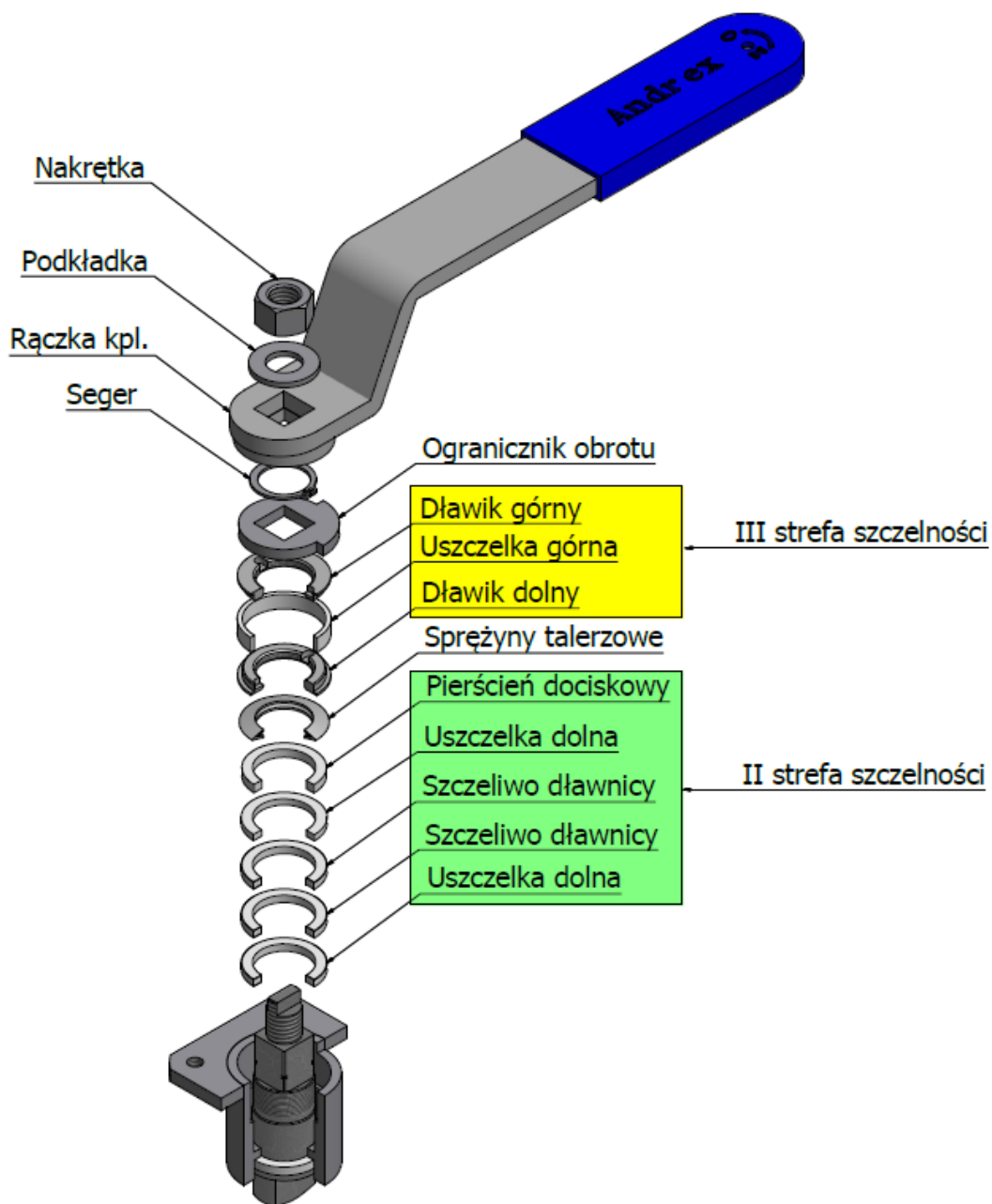

Drawing 11 Disassembly of the sealing in the stuffing box.

Nakrętka – nut; Podkładka – washer; Rączka kpl. – lever; Seger – ring; Ogranicznik obrotu – rotation limiter; Dławik górny – top gland; Uszczelka górna – top gasket; Dławik dolny – bottom gland; III strefa szczelności – third zone of sealing; Sprężyny talerzowe – disc springs; Pierścień dociskowy – follower ring; Uszczelka dolna – bottom gasket; Szczeliwo dławnicy – gland packing; Uszczelka dolna – bottom gasket; II strefa szczelności – second zone of sealing



Start dismantling the valve hand lever by closing the valve.



Pay attention to the position of ball. The milling on stem indicates the correct setting.



Unscrew the nut with a wrench suitable for the given lever, depending on the diameter, and remove the washer located under it.



Take off the outer securing ring on the ball valve stem.



Remember the setting of turn limiter for proper reassembly.



Remove the turn limiter. In order to do this, you can use two screw drivers to lever it up.



Using the special key, unscrew the upper gland counter-clockwise, which results in access to the upper sealing (III tightness zone).



In the next stage, unscrew the lower gland counterclockwise, which results in the relaxation of the disc springs supporting the main sealing.



Replace the sealing package in the II tightness zone for another one, depending on the needs according to manufacturer's recommendations.



Reassemble all parts in reverse order.

## 7. Change of steering devices.

The steering equipment is not an integral element of the ball valve, which increases the possibility of equipping it with additional elements. The universality of attaching additional elements enables the connection of a column or an extension adapted to the assembly of all actuators or drives made in accordance with the PN-EN ISO 5211: 2005 standard. In order to dismantle the standard complete lever and install another steering element, follow the instructions presented.

### 7.1 Disassembly of steering hand lever



Start dismantling the valve hand lever by closing the valve.



Unscrew the nut with the wrench suitable for the lever, depending on the diameter, and remove the washer located under it.



Remove the complete lever from the ball valve stem with the firm movement directed perpendicularly to the ball valve.

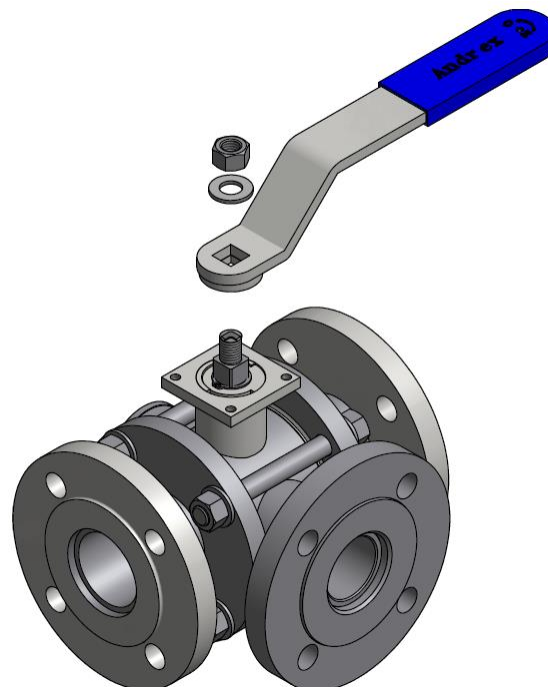

Drawing 12 Disassembly of hand lever.

## 7.2 Assembling of column



In order to assemble efficiently the column, it is suggested to prepare and check all the parts included in the new system before disassembling the previous steering system.



Unscrew the nut with a wrench suitable for the hand lever, depending on the diameter, and remove the washer located under it.

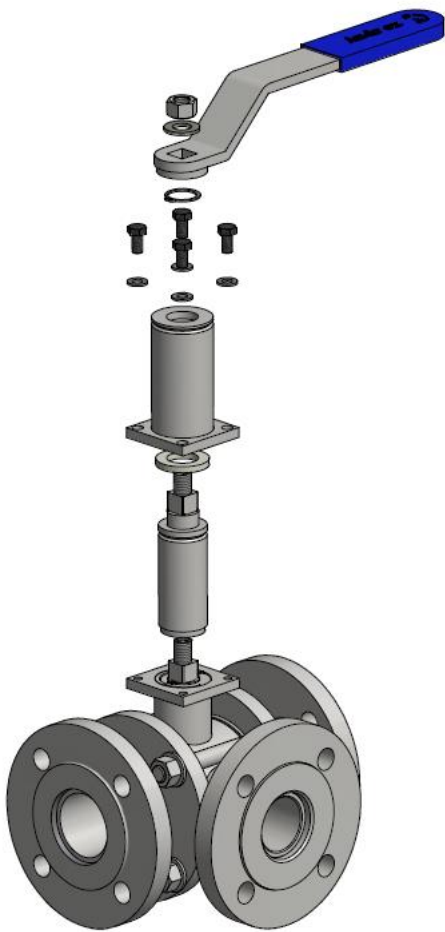

Put the column stem on the ball valve stem, paying particular attention to the ball position indicator.



Put the spacer sleeve together with the column housing on the column stem. Align the mounting holes with the holes on the gland flange.



Install the column housing with the gland flange using the screws and washers specified by the manufacturer.



Put on the outer protection ring on the column stem.



Put on the complete lever on the ball valve stem and fasten it with a nut and washer.

Drawing 13 Assembling of column with lever.

### 7.3 Assembling of actuator mounting



In order to assemble efficiently the actuator mounting, it is suggested to prepare and check all the parts included in the new system before disassembling the previous steering system.

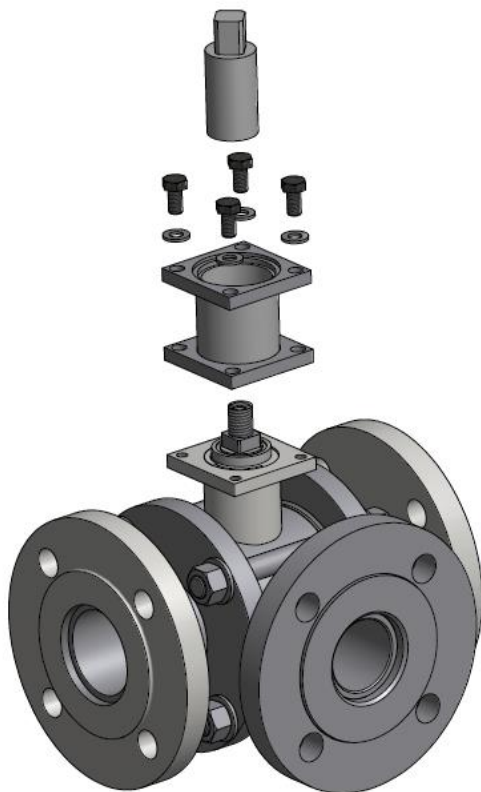

After dismantling the previous steering system, put on the actuator stem on the ball valve stem.



Put on the actuator mounting, paying attention to the position of the mounting holes.



Secure the actuator mounting to the stuffing box flange using the screws and washers specified by the manufacturer.



Install the steering accessories according to manufacturer's installation instructions and calibrate it for proper operation.



Pay particular attention to the position of the turn limiter and the position in which it operates.

Drawing 14 Assembly of actuator mounting.

The actuator mounting is adapted in accordance with the PN-EN ISO 5211 standard – Industrial valves and fittings - connections of the part-turn valve actuators. A variety of steering solutions can be attached to the correctly assembled actuator mounting element. Examples are presented in the drawing below.

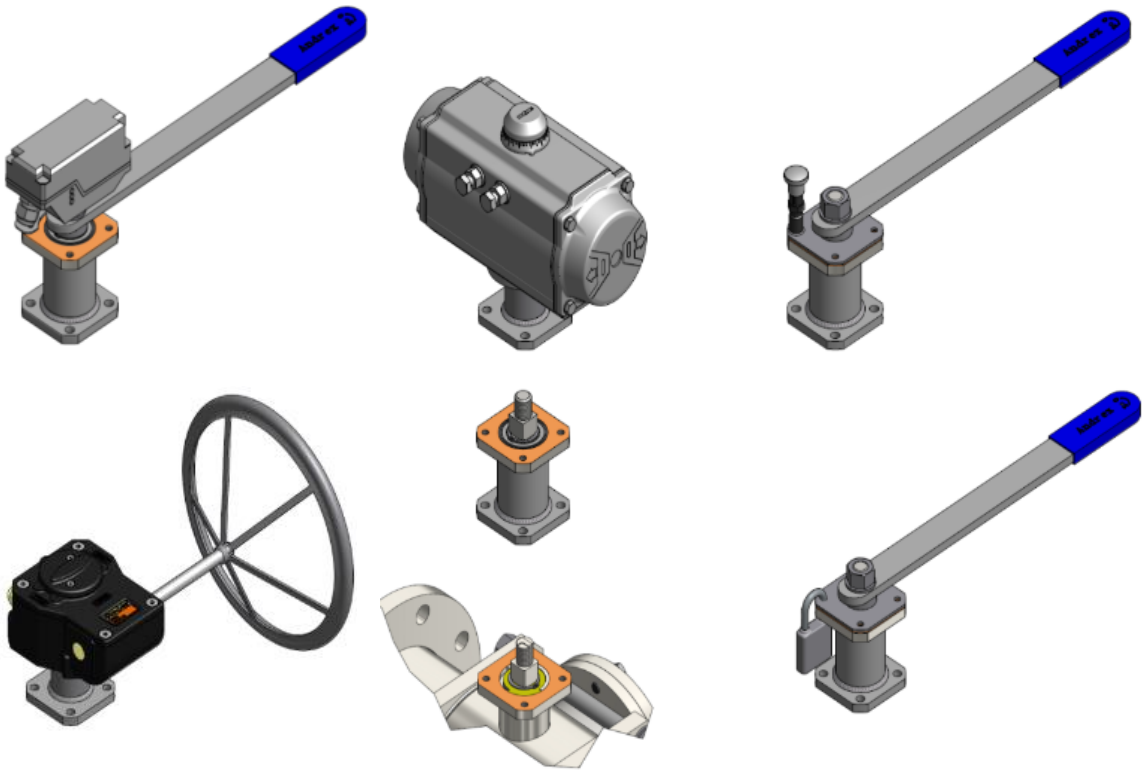

Drawing 15 Examples of valve steering solutions.

#### 7.4 Lever with return spring.

Periodic functional inspection should be carried out after the spring return control lever has been used for quite some time. In order to carry out this, you need to get to the nut that regulates it's tension by removing the end cap and the spring housing. After tightening the adjusting nut clockwise and obtaining the appropriate pre-tension, install the spring housing with the end cap.

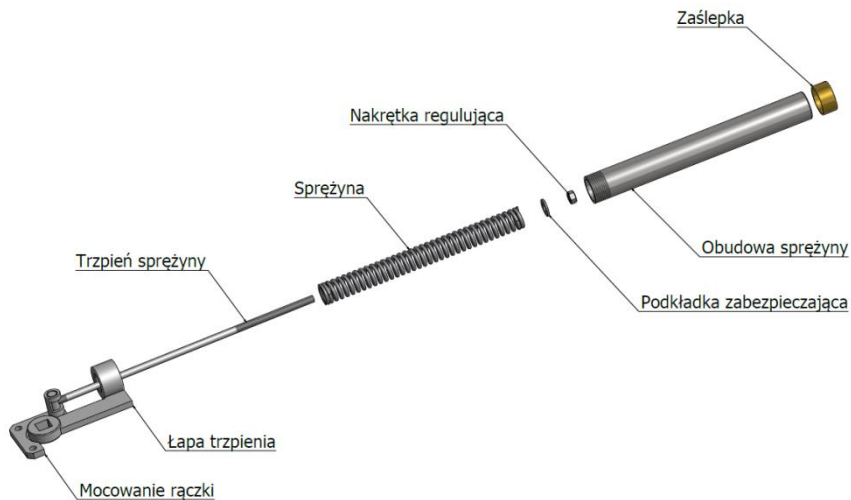

Drawing 16 Construction of lever with a return spring.

Zaślepka – plug; Obudowa sprężyny – spring housing; Nakrętka regulująca – regulating nut; Podkładka zabezpieczająca – safety washer; Sprężyna – spring; Trzpień sprężyny – spring stem; Łapa trzpienia – stem base ; Mocowanie rączki – lever mouting.

To remove the spring return lever to install other steering device:



Start dismantling the valve steering lever by closing the valve.



Pay attention to the position of ball. The milling on the stem indicates the correct setting.



Remove the spring housing plug and then counterclockwise unscrew the spring housing.



Unscrew the adjusting nut and remove the spring from the stem.



Note the position of the adjusting nut for possible reassembly.



Disassemble the nut securing the stem lug to the ball valve stem and unscrew the screws securing the lever to the gland collar.



Remove the entire steering unit by pulling vertically upwards.

## 8. Options of ball setting in multiway valves

In multi-way valves, we use balls with "L" and "T" passages. Drawings 18, 19 and 20 show standard solutions for assembling the appropriate ball. The ball can also be oversteered on the already assembled valve according to our manual. In order to make this change, please contact the service immediately.

Ball „T”				
Rotation angle	1T – 180°	2T – 180°	3T – 180°	4T – 180°
starting position. rotation angle - 0°				
Intermediate position. rotation angle - 90°				
Final position. rotation angle - 180°				

Drawing 17 Options of use of ball type „T”. Maximum angle of rotation – 180°.

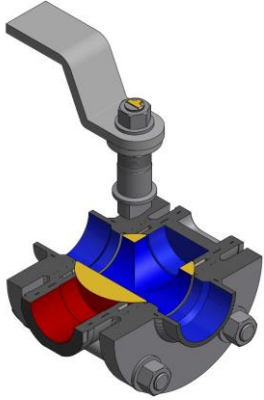
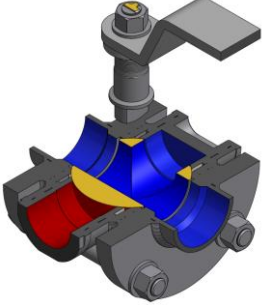
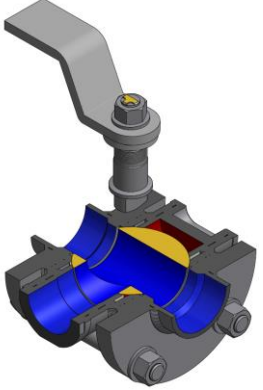
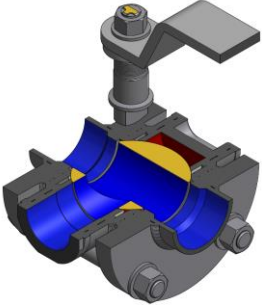
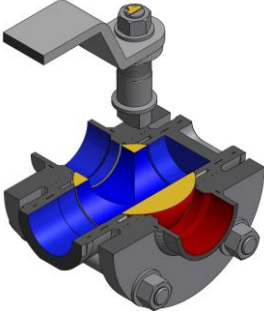
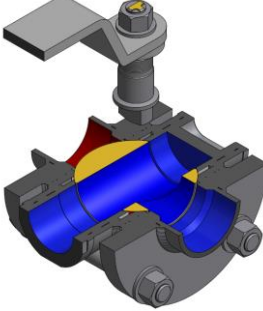
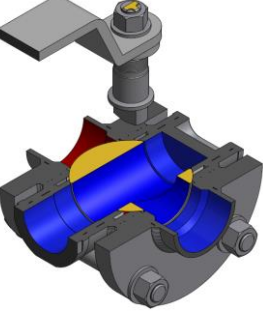
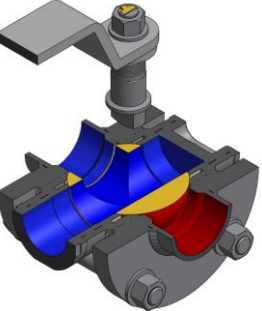
Ball „T”				
Rotation angle	5T – 90°	6T – 90°	7T – 90°	8T – 90°
Starting position. rotation angle - 0°				
Final position. rotation angle - 90°				

Drawing 18 Options of use of ball type „T”. Maximum angle of rotation – 90°.

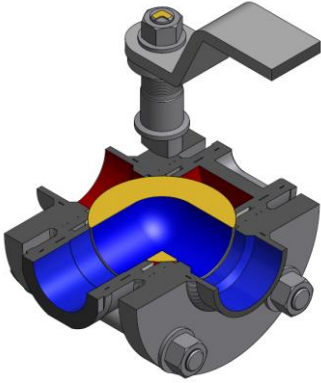
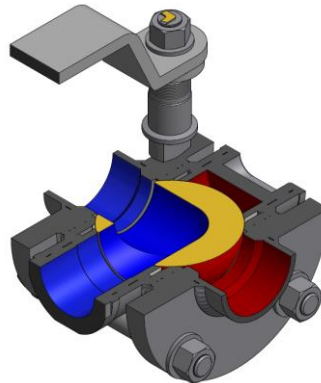
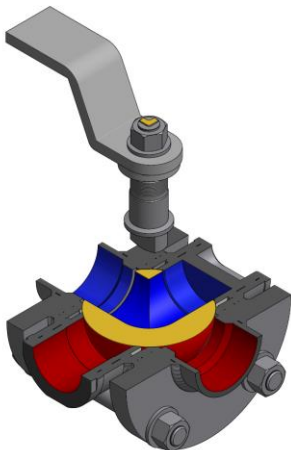
Ball „L”	
Rotation angle	1L – 180°
Starting position. rotation angle - 0°	
Intermediate position. rotation angle - 90°	
Final position. rotation angle - 180°	

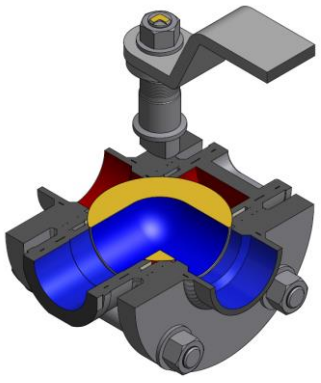
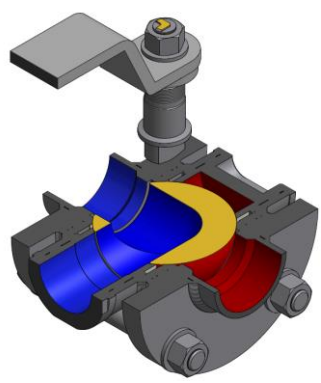
Ball „L”	
Rotation angle	2L – 90°
Starting position. rotation angle - 0°	
Final position. rotation angle - 90°	

Drawing 19 Options of use of ball type „L”. Rotation angle – 180° or 90°.

	No medium		Steering element		Flowing medium
--	-----------	---	------------------	--	----------------

## 9. Maximum static torque in ball valves



To maintain proper operation of ball valve, do not exceed the maximum static torque on the stem when opening or closing.

<b>DN</b>	<b>Maximum static torque [Nm]</b>
<b>15</b>	<b>40</b>
<b>20-32</b>	<b>120</b>
<b>40</b>	<b>140</b>
<b>50-80</b>	<b>300</b>
<b>100-125</b>	<b>1000</b>
<b>150</b>	<b>1200</b>
<b>200-250</b>	<b>3000</b>

**APPENDIX NO 1**

**INCORRECTNESS APPLICATION FOR VALVES AND FITTINGS**

**I . APPLICANT**

- 1. Full Name: .....
- 2. Company Name: .....
- 3. Address: .....
- 4. Phone number: .....

**II. DATA REGARDING LOCALISATION OF VALVES AND FITTINGS**

- 1. User Name: .....
- 2. Assembly address: .....
- 3. Assembly date: .....
- 4. Contact person: .....

**III. INFORMATION ABOUT VALVES AND FITTINGS**

- 1.Type: .....
- 2. Quantity .....
- 3. Serial number: .....
- 4. Purchase date: .....
- 5.Order number: .....
- 6. Invoice number: .....
- 7. Medium and conditions of valves and fittings installation: .....

**IV. DESCRIPTION OF INCORRECTNESS**

.....  
.....  
.....  
.....

Application date .....

Applicant signature .....